

# LRC Products, Inc.

Engineered Wood — We do it better because it's all we do!

Sales: 800-348-2326 ~ Corporate: 574-267-6561 ~ Fax: 574-267-8572 ~ P.O. Box 737 Warsaw, Indiana 46581

E-Mail: sales@lrcproducts.com ~ Web: www.lrcproducts.com ~ www.expressheader.com

## Cutting Holes in Solid Sawn Floor Joists

International Code R502.8.1 Sawn Lumber.

Notches in solid lumber joists, rafters and beams shall not exceed one-sixth of the depth of the member, shall not be longer than one-third of the depth of the member and shall not be located in the middle one-third of the span. Notches at the ends of the member shall not exceed one-fourth the depth of the member. The tension side of the members 4 inches or greater in nominal thickness shall not be notched except at the ends of the members. The diameter of holes bored or cut into members shall not exceed one-third the depth of the member. Holes shall not be closer than 2 inches to the top or bottom of the member. Where the member is also notched, the hole shall not be closer than 2 inches to the notch.

Excerpt taken from the 2000 International Residential code book page 84

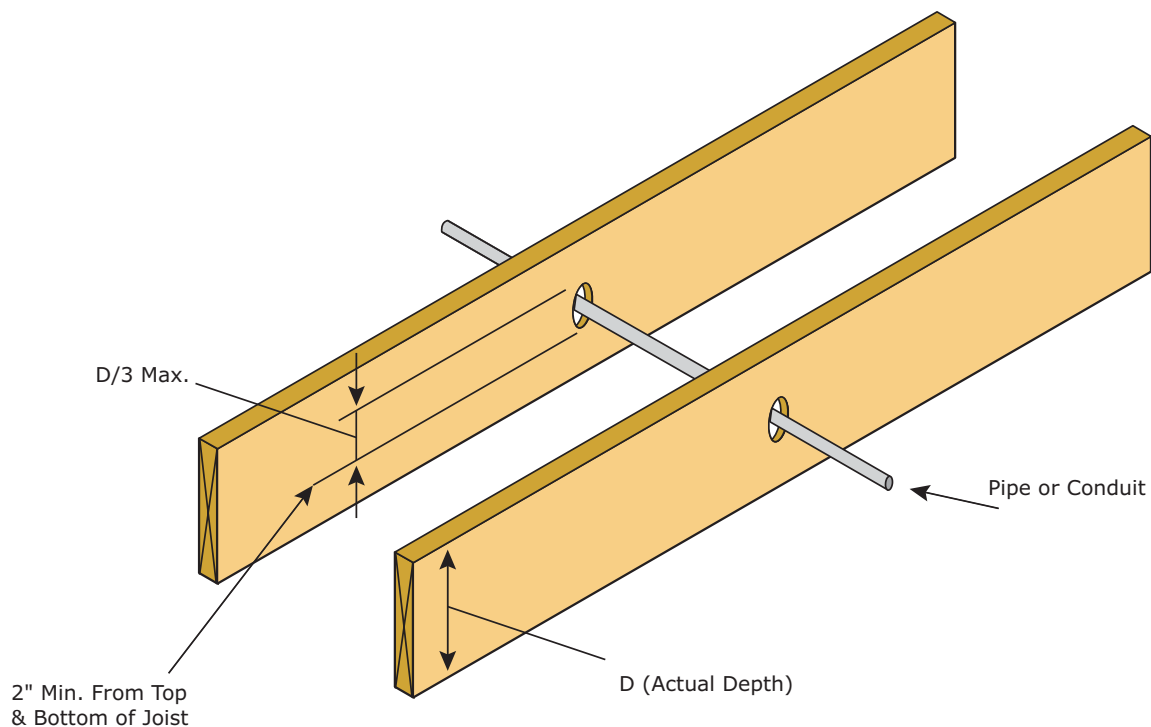

Figures R502.8  
CUTTING, NOTCHING AND DRILLING